

| REV. | EN. NO. | APPD. |
|------|---------|-------|
| A0 | | |

- NOTES:
- MATERIAL: HTN WITH 30% GF. UL 94V-0, BLACK COLOR.
HOUSING: HTN WITH 30% GF. UL 94V-0, BLACK COLOR.
SPACER: HTN WITH 30% GF. UL 94V-0, BLACK COLOR.
CONTACT: PHOSPHOR BRONZE, 0.35 THICKNESS.
FRONT SHIELD: BRASS, 0.30 THICKNESS.
REAR SHIELD: COLD ROLL STEEL, 0.30 THICKNESS.
GROUNDING STRIP: STAINLESS STEEL, 0.15 THICKNESS.
 - FINISH:
CONTACT: G/F PLATING ON CONTACT AREA.
FRONT SHIELD: 2.54mm [100m²] MIN. MATTE TIN PLATING ON SOLDER TAIL.
REAR SHIELD: 1.016mm [40m²] MIN. NICKEL UNDERPLATING OVERALL.
GROUNDING STRIP: 1.27mm [50m²] MIN. NICKEL PLATING.

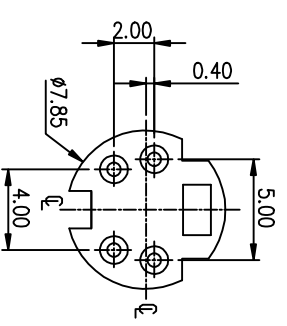
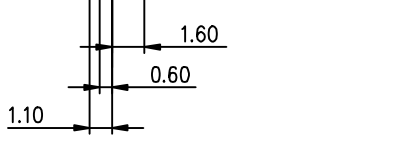
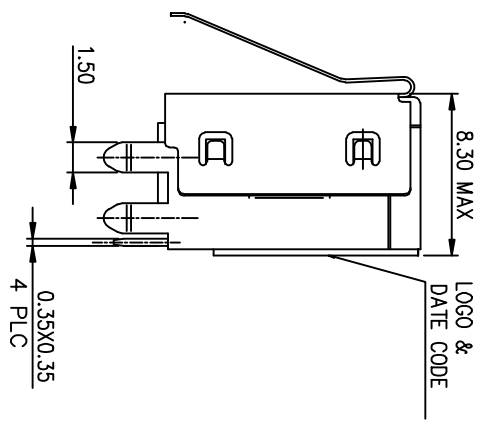
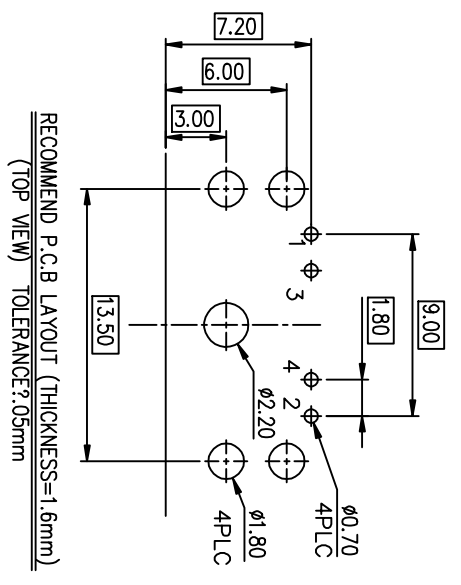

PART NO. DESCRIPTION: MAD05 - 04 1 A N 0 *

MINI DIN: _____ MARK

PDS NO.: _____ PACKAGE

04=4PDS. 0=TRAY

COLOR: _____ SHELL PLATING:
1=BLACK N=NICKEL PLATING

CONTACT +SOLDER PLATING: _____

A=1~3U" GOLD PLATING + 100U" MIN. MATTE TIN

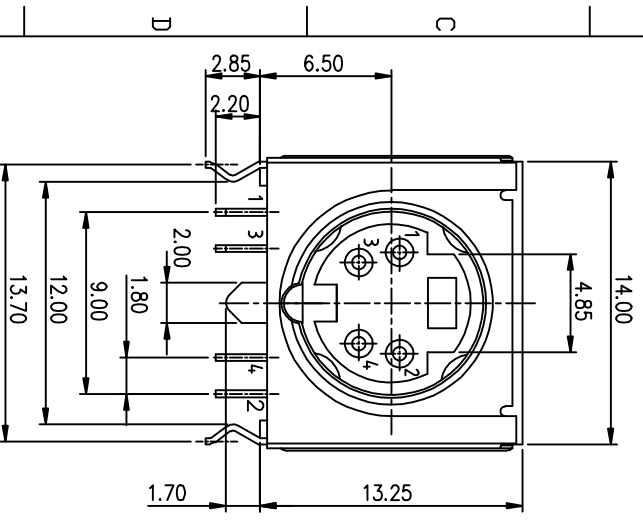

| | | | | |
|------------------|-----|--------|-----------------------|-------------------------------|
| INTENDED USE | QTY | FINISH | FILE NO. | TITLE |
| CUSTOMER | | | C-MAD05-00-A0 | VAD ITEM, SLIM MINI DIN 4P |
| PART NO. | | | APPD. KE VIN 12/30/08 | DWG NO. C-MAD05-00-A0 |
| MAD05-04LANDK | | | CHKD. LING 12/30/08 | REV. A0 |
| TOLERANCES | | | DR. LING 12/30/08 | |
| X ± 0.38 X ± | | | SCALE: 1:1 | SHEET: 1/1 |
| .XX ± 0.25 .XX ± | | | | |

HT HUNG TA HI ENTERPRISE CO., LTD