

REV.	ECN NO.	APPD.
A	DWG REL	

ITEM 項目	PARTS NAME 零件名稱數量	Q'TY	MATERIAL 材質	FINISH/REMARK 處理/備註
1	HOUSING	1	SYNTHETIC RESIN	(Black)
2	CONTACT	5	COPPER ALLOY	CONTACT AREA:GOLD FLASH SOLDER TAILS:100u" Tin Base Nickel:50u"
3	SHELL	1	STAINLESS	PLATING Ni:20u"

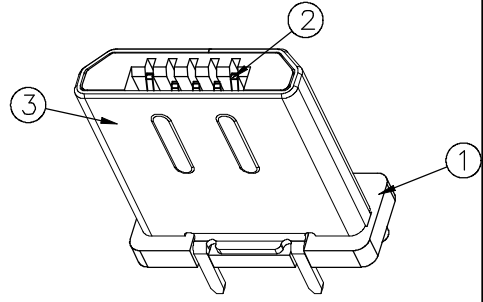
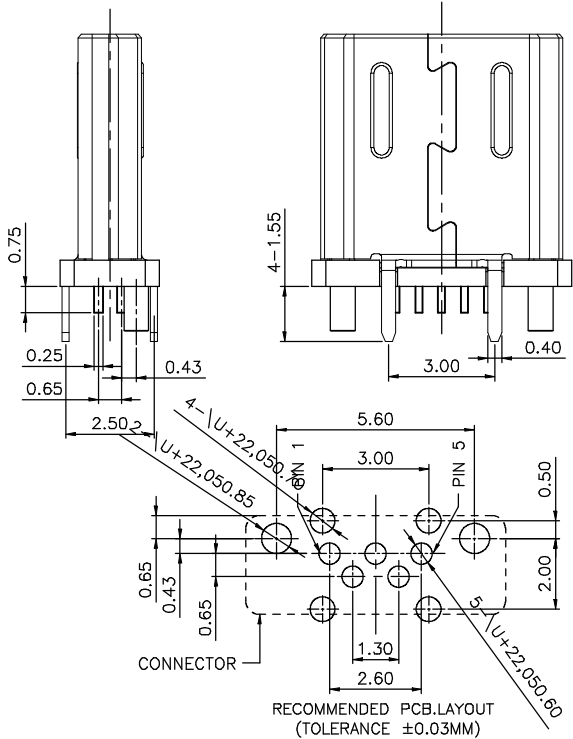
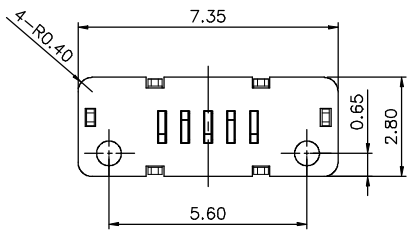
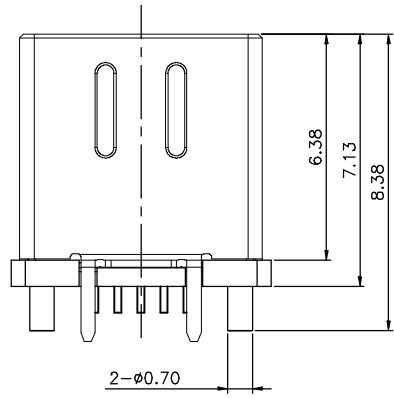
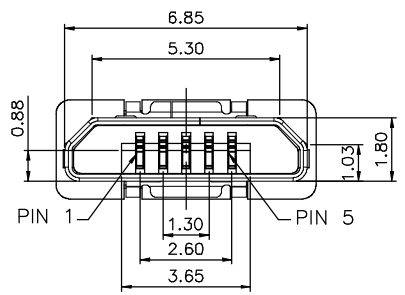

- NOTES
- 1.MATERIAL: See drawing
  - 2.ELECTRICAL
    - 2.1.Insulator resistance: 100M ohms Min. @ 500 VDC
    - 2.2.Withstanding voltage: 100 VAC / minute
    - 2.3.Contact resistance: 60m ohms Max.
  - 3.MECHANICAL
    - 3.1.Mating force: 35N(3.43kgf) Max.
    - 3.2.Durability: 10000 cycles Min.
    - 3.3.Contact retention force: 2.1N(0.21kgf) Min
  - 4.PACKING: 500pcs/bag (reference)

BUP02 - 05 1 1 N 2 0  
① ② ③ ④ ⑤

- ① HOUSING COLOR  
1:BLACK
- ② CONTACT PLATED  
1:G/F
- ③ SHELL PLATED  
N: NICKEL
- ④ PACKAGE  
3:BAG
- ⑤ MARK  
0: NO MARK

INTENDED USE	Q'TY	HUNG TA H.T.ENTERPRISE CO.,LTD	
PART NO. BUP02-0511N20	FINISH	FILE NO. C-BUP02-00-A0	TITLE MICRO USB-B TYPE (VERTICAL)
TOLERANCES X ± 0.35 X ± 3° .XX ± 0.25 .XX ±	MAT'L	APPD: HONDA 20131021 CHKD: LONG 20131021 DR: LONG 20131021	DWG NO: C-BUP02-00-A0 REV. A
		SCALE N/A	SHEET 1 OF 1