

RoHS Complied

REV.	ECN. NO.	APPD.
A	DWG. REL.	

SPECIFICATIONS:

- 1.INSULATION RESISTANCE:500MΩ OR MORE
THE TEST VOLTAGE OF 500VDC
- 2.CONTACT RESISTANCE:30mΩ OR LESS
- 3.VOLTAGE PROOF:500V AC FOR ONE MINUTE
- 4.INSERTION FORCE:10N~20N
- 5.WITHDRAWAL FORCE:7N~13N Δ
- 6.WATER PROOFNESS: This product is based on IPX8(2m,30min)
- 7.USING PLUG: ϕ 3.5MM、4-POLE STEREO EARPHONE(LCH/RCH/GND/MIC)
PROVIDED THAT THEY CONFORM TO JIS C6560

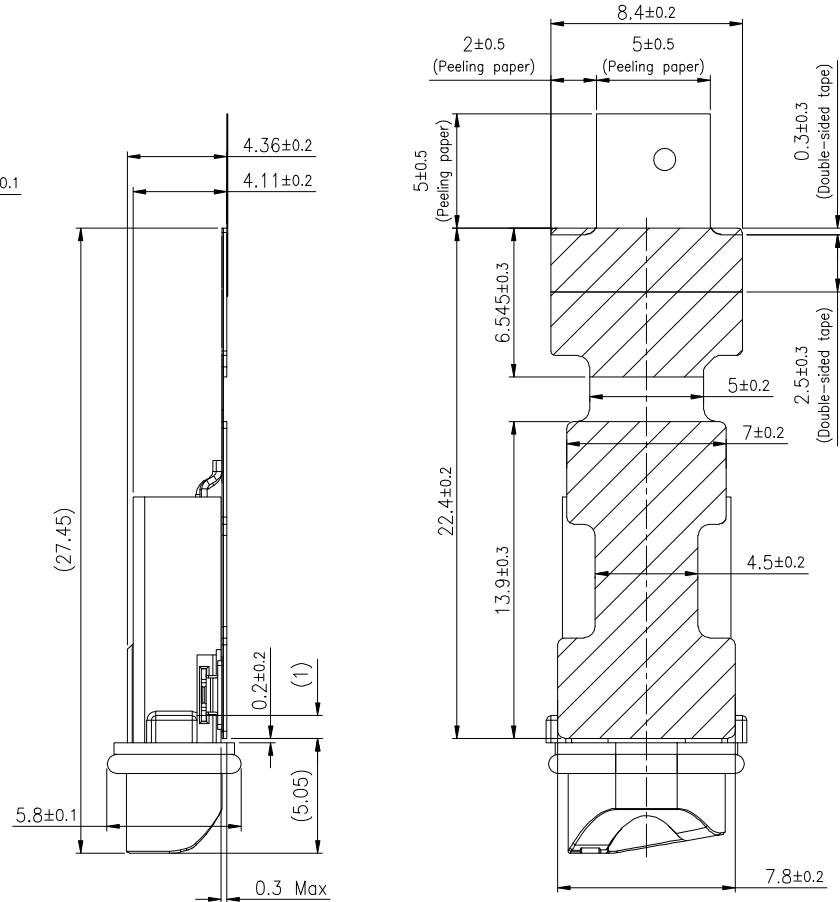
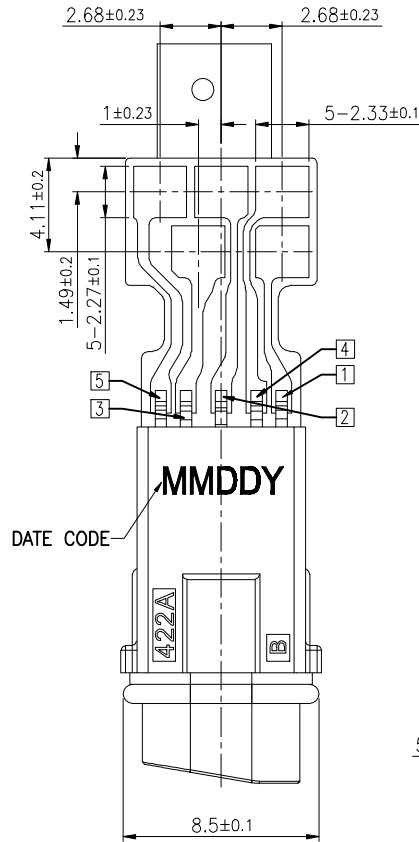

AAR38-05 * * A * *

- ① HOUSING COLOR
1:BLACK
- ② CONTACT GOLD PLATED
W:G/F
- ③ SHELL PLATING
A:NO SHELL
- ④ PACKAGE
0:TRAY
- ⑤ MARK
0:NO MARK

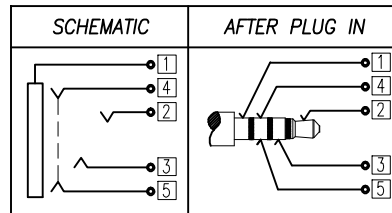
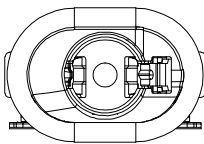
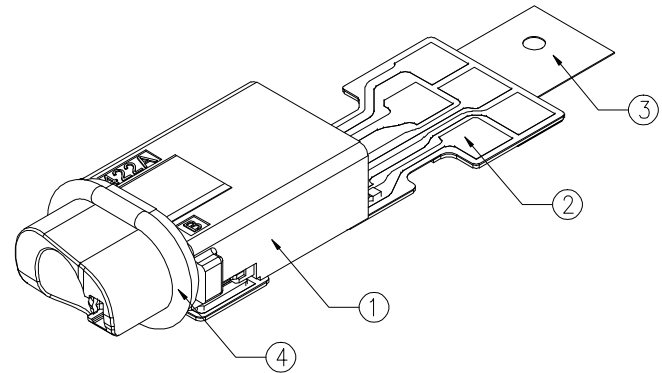

□ : TERMINAL NO.

④	O-RING	----	1	----	----
⑤	DOUBLE-SIDED TAPE	----	1	----	----
②	FPC	----	1	----	----
①	WATERPROOF JACK	----	1	----	----
ITEM	PART NAME	TERMINAL	QTY	MATERIAL	REMARK
INTENDED USE		QTY		FINISH	
PART NO.		FILE NO.		TITLE:	
AAR38-051WA**		C-AAR38-00-A0		C-AAR38-00-A0	
TOLERANCES		MAT'L		APPD: HONDA 20151228	
.X ± 0.35 .X ±				DWG NO.:	
.XX ± 0.25 .XX ±				C-AAR38-00-A0	
				APPD: HONDA 20151228	
				CHKD: LONG 20151228	
				DR: LONG 20151228	
				SCALE 1:1	
				SHEET 1 OF 1	